

# TECHNOLOGY GROWTH FOR THE 80's

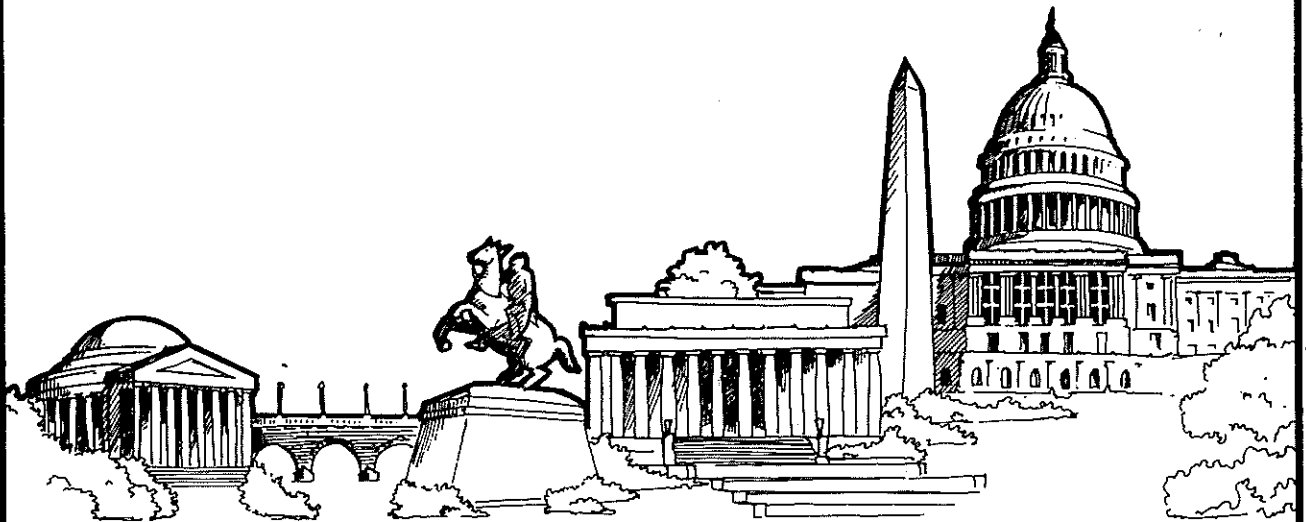

## 1980 IEEE MTT-S INTERNATIONAL MICROWAVE SYMPOSIUM DIGEST

28-30 MAY 1980, WASHINGTON, D.C.

**NHK** 技研



N0820311900

**NHK** 技研

N0820311900



IEEE CATALOG NO. 80CH1545-3 MTT



MAIN TRANSMIT AND RECEIVE STATION IN JAPANESE BSE PROGRAM  
 Nobuo Imai, Yuichi Otsu and Takashi Tanaka  
 Radio Research Laboratories—Ministry of Posts and Telecommunications  
 2-1, Nukui-Kitamachi 4-chome,  
 Koganei-shi, Tokyo, 184 Japan

Introduction

The Japanese Medium-scale Broadcasting Satellite for Experimental Purpose (BSE) was launched successfully in April, 1978 and placed on the geostationary orbit of longitude 110 deg. E.. After the spacecraft initial performance check-up on orbit made by the National Space Development Agency of Japan (NASDA), the various broadcasting experiments were started in July, 1978, and will be conducted for about three years by the Radio Research Laboratories (RRL) of Ministry of Posts and Telecommunications (MOPT) and the Japan Broadcasting Corporation (NHK) in close cooperation with NASDA.

The MTRS was installed as the key station for the BSE experiments and has been operating satisfactorily. In this paper are reported the system configuration, functions and characteristics of MTRS together with a brief description of the total experimental system in Japanese BSE program.

BSE Experimental System

There are many earth terminals which participate in the BSE program as shown in Fig. 1. They are Main Transmit and Receive Station (MTRS) of RRL, two types of Transportable Transmit and Receive Stations (TTRS), three types of Receive-Only Stations (ROS) and many Simple Receive Equipments (SRE). All these earth terminals except MTRS were prepared by NHK. NASDA is responsible for the control and maintenance of the satellite during the experimental period. This diagram includes also the operational control center and TT&C stations of NASDA. These stations are connected with telephone, facsimile and data communication links so as to carry out various BSE experiments effectively. MTRS is also linked with NASDA's tracking network.

The satellite antenna has a suitable radiation pattern as shown in Fig. 2 for providing high quality color TV broadcasting service to the whole Japanese territory. This Figure shows the radiation pattern of BSE antenna and locations of various participating earth terminals which are plotted on a map of Japan. Also type of each earth terminal and its antenna size are indicated.

Fig. 3 shows frequency allotment for the BSE transponder. Frequency bands of 14 and 12 GHz are used for up and down links respectively. The transponder of BSE is of a frequency selective Ku-band single conversion type. It provides simultaneous two-channel TV broadcasting; one is A<sub>1</sub> or A<sub>2</sub> channel, the other is B<sub>1</sub>, B<sub>2</sub> or B<sub>3</sub> channel. Four OW channels are contained in B<sub>3</sub> channel.

Main Transmit and Receive Station

A functional block diagram of MTRS is shown in Fig. 4. MTRS is the key station of BSE program and has functions of simultaneous two-channel TV signals transmission/reception in Ku-band (14/12 GHz) and TT&C operation in Ku-band. It is also possible to transmit any two order-wire (OW) signals and to receive all four OW signals. OW channels are used in voice communications and experimental data transmission among participating earth terminals. This diagram consists of four main subsystems. They are Antenna Subsystem, Transmit and Receive Subsystem, Broadcast Terminal Subsystem and Operational Control Subsystem. The 13 mφ antenna is mounted on the roof of the three story main building.

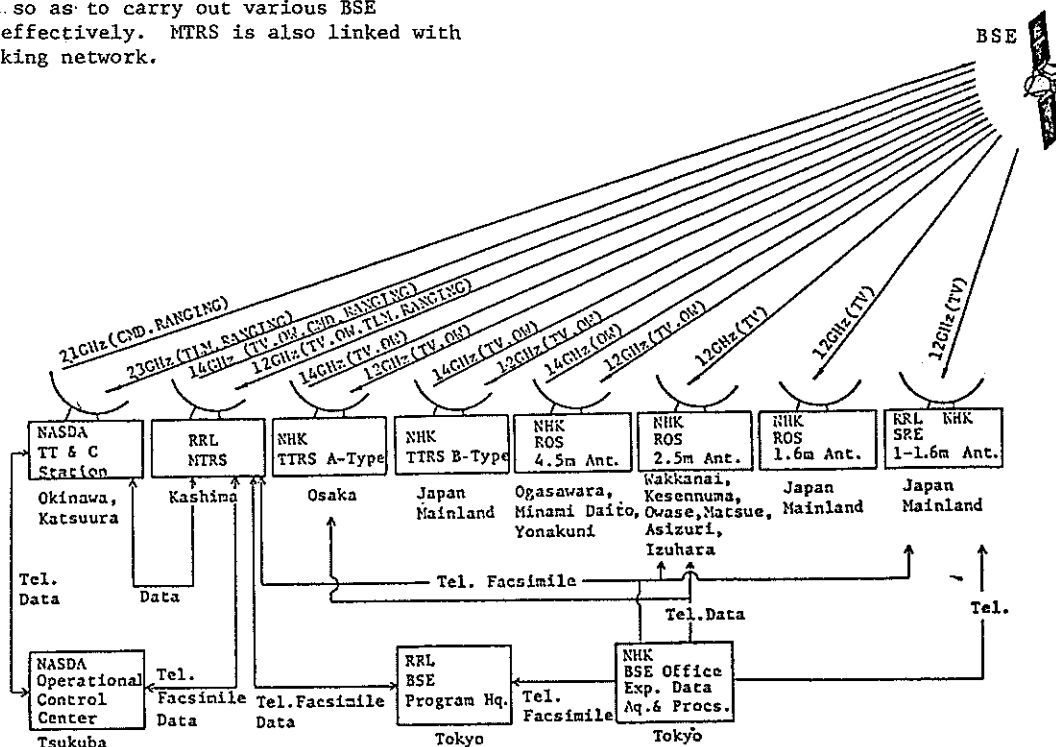

Fig. 1 The total BSE experiment system

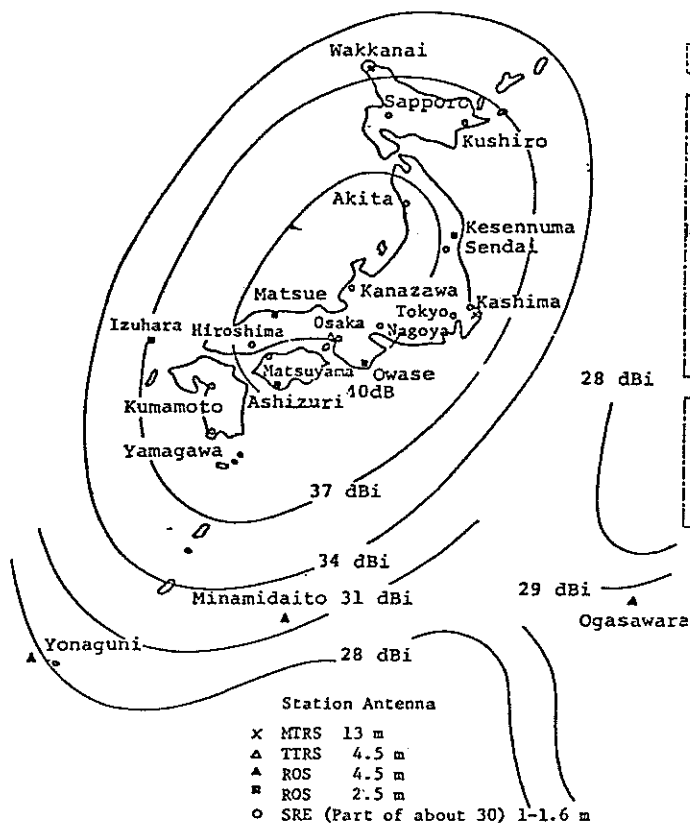

Fig. 2 The BSE antenna radiation pattern and ground station location

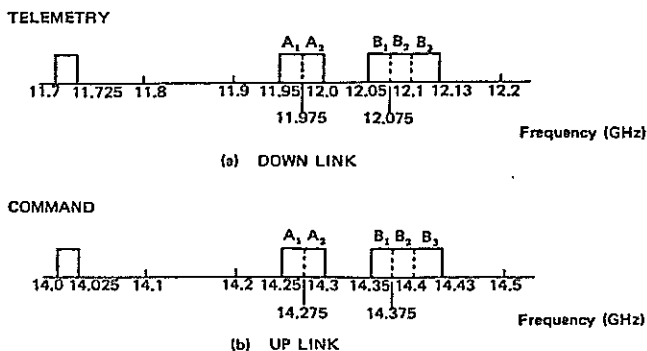

Fig. 3 Frequency arrangement for the TV transponder

IF signals from Broadcast Terminal Subsystem are up-converted to 14-GHz RF signals and power-amplified. Two TV signals (A ch & B ch) and a command signal are combined after power-amplification and fed to the antenna. By switching the route, the HPA for TV A ch can be used as a redundant system for command signal transmission. Received 12 GHz RF signals for TV and OW are directly down-converted to 297-475 MHz IF signals by a common Low Noise Converter and then to 140 MHz IF signals separately by their each down converter. Control of HPA power, channel selection, route switching, etc. and monitoring of TX & RX signal level, system noise, etc. are made at BTS TX & RX Control & Monitoring EQMT. Antenna pointing and polarization are auto-tracked. The telemetry and ranging signals are obtained from the auto-tracking receiver.

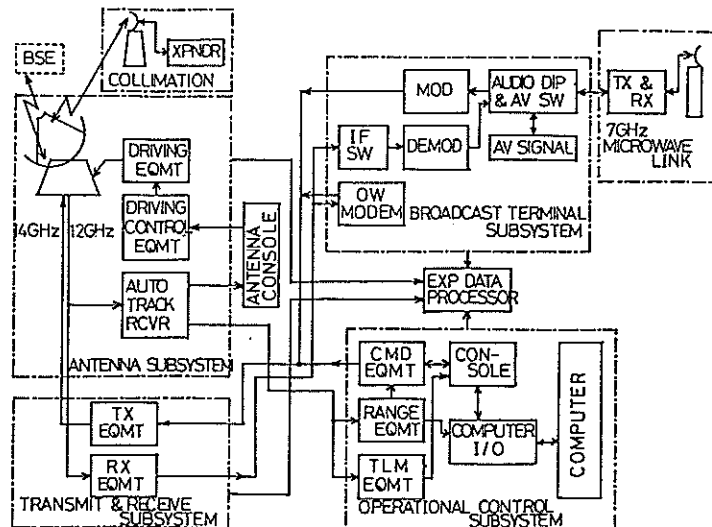

Fig. 4 Block diagram of Main Transmit & Receive Station

Table 1 System characteristics of BSE MTRS

SYSTEM SPECIFICATION	
System G/T	Above 32.0 dB (40°E1, Clear Sky)
TX E.I.R.P.	78.5-91.5 dBw/ch. (Variable)
ANTENNA SUBSYSTEM	
Type	13 m $\phi$ AZ-EL Mount
Feed System	Cassegrain Type, Beam Guide with 4 Reflectors
Gain (Include Feed Loss)	TX : 62.0 dB (14.25 GHz) RX : 61.0 dB (11.95 GHz)
Antenna Noise Temp.	Below 85°K (11.95 GHz, 40°E1, Clear Sky)
Polarization	Linear
Cross Polarization	Below -25 dB
Autotracking Accuracy	Below 0'01" RMS
Drive Range	Whole Sky
Wind Proof	Up to 60 m/sec (Instantaneous Wind Velocity)
TX SUBSYSTEM ( TWT 3 SETS )	
System Configuration	2 Channels for Broadcasting Exp. 1 Channel for TT & C
Output Power	Broadcast. Exp. : 100W-2kW/TvCh. TT & C : 200W
RX SUBSYSTEM ( with Low Noise Converter )	
System Configuration	2 Channels for Broadcasting Exp. 1 Channel for TT & C
RCVR Noise Temp.	Below 600°K

System characteristics of MTRS are shown in Table 1. It gives the system specification and the characteristics of Antenna Subsystem, Transmit and Receive Subsystem.

Fig. 5 shows an example of measured amplitude, delay, DG and DP characteristics of overall BSE link. These characteristics were measured in the satellite loop-back, including both characteristics of satellite transponder and MTRS. It is seen from these measurement results that BSE links have excellent RF transmission characteristics as a television signal transmission links.

A block diagram of operational control subsystem is shown in Fig. 6. The telemetry and command system is used to encode and transmit command signals to BSE with verification function and to process BSE house-keeping data and various on-board spacecraft experimental data. The ranging EQMT measures the range between BSE and MTRS with tones in the same way as the NASA STDN R & RR system.

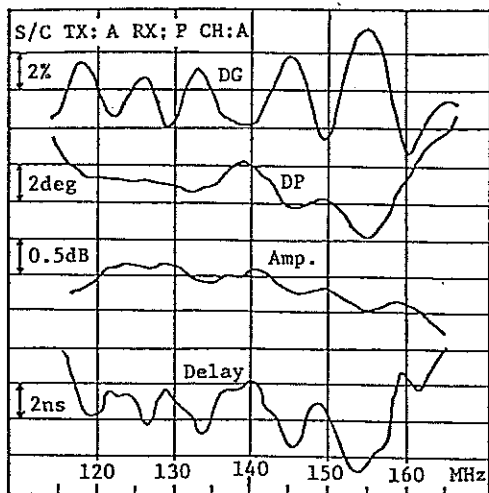

Fig. 5 Amplitude, delay, DG and DP characteristics of link

Table 2 Characteristics of rain radar

Item	Performance
Antenna control	0 ~ 360° (Az)
scanning range	0 ~ 90° (El)
pointing accuracy	± 0.3° (3 σ)
scanning rate	6 rpm (Az) 7.9°/s (El)
Transmitter and Receiver	
peak power	250 kW
pulse width	0.5 μs
pulse frequency	900 pps
RF frequency	5,330 MHz
IF frequency	30 MHz
receiving band width	2.25 MHz
noise figure	7.7 dB
min. receiving power	— 102.7 dBm
linearity of log. amp.	better than 0.5 dB for 75 dB range
max. detection range	100 km
min. detection range	300 m
pulse-hit no. for averaging	32
detectable rainfall rate	0.1 mm/h (Min.) 150 mm/h (Max.)

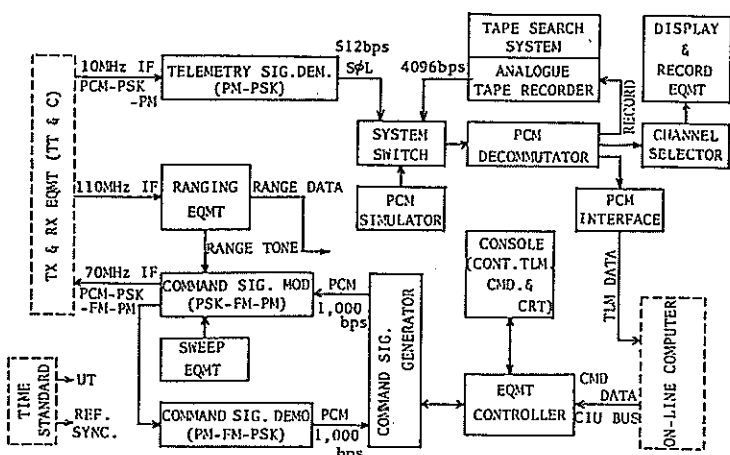

Fig. 6 Block diagram of operational control subsystem

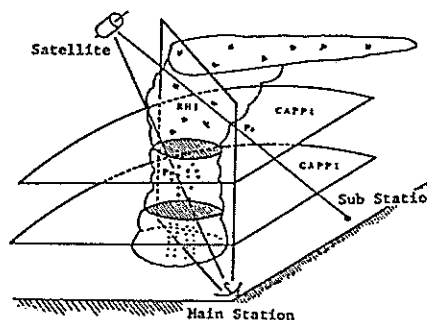

Fig. 7 Schematic illustration of radar data mode

#### Acknowledgement

The authors wish to express their sincere thanks to the contributions made by MOPT, RRL, NHK, and Toshiba staffs in promoting the BSE project.

#### References

- (1) K. Tsukamoto et al., "Main Transmit and Receive Station of BSE Program," 12 th International Symposium on Space Technology and Science, Tokyo, 1977.
- (2) K. Tsukamoto et al., "Technical Aspects of the Japanese Broadcasting Satellite Experiments" IEEE Trans. Broadcasting, vol. BC-24, No. 4, Dec. 1978
- (3) N. Imai et al., "Experimental Results of the Japanese BSE Program" IAF Paper IAF-79-F-280, Sept. 1979
- (4) T. Ishida et al., "Present Situation of Japanese Satellite Broadcasting for Experimental Purpose", IEEE Trans. Broadcasting, vol. BC-25, No. 4, Dec. 1979

#### Conclusion

BSE broadcasting experiments have been conducted since July 1978, and MTRS has been playing the key role giving fruitful experimental results. On the basis of the good results in the BSE project, the operational broadcasting satellite BS-2 is now under consideration. It is expected to be launched in 1983 fiscal year with an on-orbit spare satellite.